

Write your name here

Surname

Other names

**Pearson Edexcel
International GCSE**

Centre Number

--	--	--	--	--

Candidate Number

--	--	--	--

Mathematics A

Paper 2FR



Foundation Tier

Thursday 7 June 2018 – Morning
Time: 2 hours

Paper Reference

4MA0/2FR

You must have:

Ruler graduated in centimetres and millimetres, protractor, compasses, pen, HB pencil, eraser, calculator. Tracing paper may be used.

Total Marks

--

Instructions

- Use **black** ink or ball-point pen.
- **Fill in the boxes** at the top of this page with your name, centre number and candidate number.
- Answer **all** questions.
- Without sufficient working, correct answers may be awarded no marks.
- Answer the questions in the spaces provided
– *there may be more space than you need.*
- **Calculators may be used.**
- You must **NOT** write anything on the formulae page.
Anything you write on the formulae page will gain NO credit.

Information

- The total mark for this paper is 100.
- The marks for **each** question are shown in brackets
– *use this as a guide as to how much time to spend on each question.*

Advice

- Read each question carefully before you start to answer it.
- Check your answers if you have time at the end.

Turn over ►

P53382A

©2018 Pearson Education Ltd.

1/1/1/



Pearson

International GCSE MATHEMATICS
FORMULAE SHEET – FOUNDATION TIER

Pythagoras' Theorem
 $a^2 + b^2 = c^2$

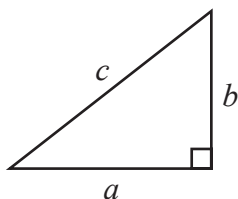

Area of a trapezium = $\frac{1}{2}(a + b)h$

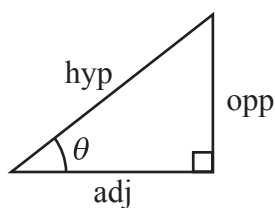
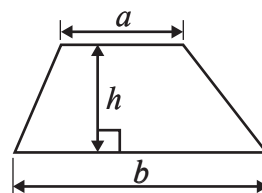

adj = hyp \times cos θ
 opp = hyp \times sin θ
 opp = adj \times tan θ

Volume of prism = area of cross section \times length

or $\sin \theta = \frac{\text{opp}}{\text{hyp}}$

$\cos \theta = \frac{\text{adj}}{\text{hyp}}$

$\tan \theta = \frac{\text{opp}}{\text{adj}}$

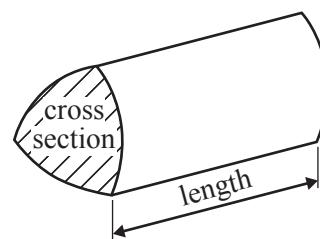

Circumference of circle = $2\pi r$

Area of circle = πr^2

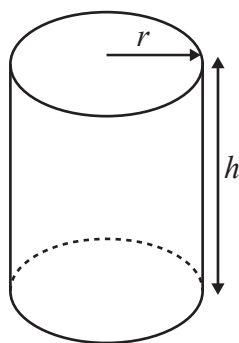

Volume of cylinder = $\pi r^2 h$

Curved surface area of cylinder = $2\pi r h$

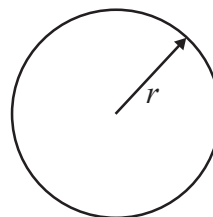

DO NOT WRITE IN THIS AREA

DO NOT WRITE IN THIS AREA

DO NOT WRITE IN THIS AREA



DO NOT WRITE IN THIS AREA

DO NOT WRITE IN THIS AREA

DO NOT WRITE IN THIS AREA

Answer ALL TWENTY FIVE questions.

Write your answers in the spaces provided.

You must write down all the stages in your working.

1 (a)

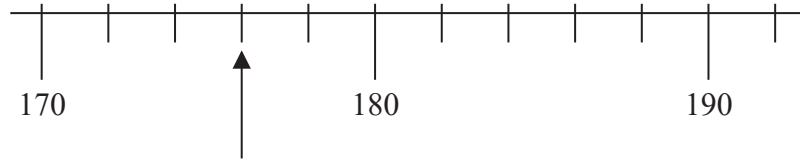

Write down the number marked with the arrow.

.....
(1)

(b) (i)

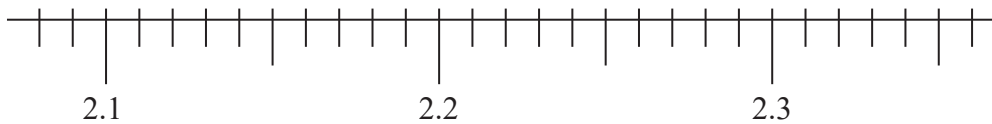

Mark with an arrow (↑) the number 2.28

(ii) Write a number on the dotted line to make the calculation correct.

$$2.18 + \dots\dots\dots = 2.26$$

(2)

(c) Write these decimals in order of size.
Start with the smallest decimal.

0.063 0.6 0.07 0.77 0.0011

.....
(1)

(d) Find the number that is exactly halfway between 12.9 and 13.7

.....
(2)

(Total for Question 1 is 6 marks)



2 (a) Complete the following sentences by writing a sensible metric unit on each of the dotted lines.

(i) The amount of water in a glass is 200

(ii) The width of a book is 16

(2)

(b) Change 4.3 kilometres into metres.

.....metres

(1)

(Total for Question 2 is 3 marks)

3

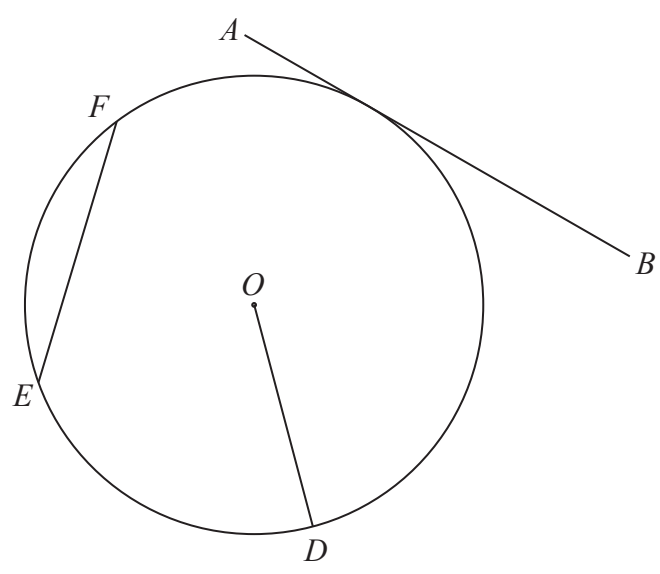

The diagram shows a circle, centre O .
 D , E and F are points on the circle.
The line AB touches the circle.

Write down the mathematical name for the line

(i) AB

.....

(ii) OD

.....

(iii) EF

.....

(Total for Question 3 is 3 marks)



4 (a) Write the number **six thousand and seventy nine** in digits.

.....
(1)

(b) Write down the value of the 4 in the number 9417

.....
(1)

(c) Write the number 72.163 correct to 1 decimal place.

.....
(1)

(d) Write down two multiples of 18

..... and
(1)

(e) Write 0.7 as a percentage.

..... %
(1)

(f) Write brackets in this calculation so that the answer is correct.

$$25 + 3 \times 7 - 2 = 40$$

(1)

Here is a list of numbers.

- 9235 9842 6386 8607 9417

(g) Write down the smallest odd number in the list.

.....
(1)

(Total for Question 4 is 7 marks)



- 5 Mahtab asks the students in her class how many brothers they each have. Here are her results.

2 1 3 4 1 0 0 2 3 1
2 2 3 1 1 0 2 4 1 1

- (a) Complete the frequency table for her results.

Number of brothers	Tally	Frequency
0		
1		
2		
3		
4		

(2)

- (b) Write down the modal number of brothers.

.....
(1)

- (c) Write down the fraction of these students who have no brothers.

.....
(1)

(Total for Question 5 is 4 marks)



DO NOT WRITE IN THIS AREA

DO NOT WRITE IN THIS AREA

DO NOT WRITE IN THIS AREA

6 The table shows the lowest temperature on one day in December for each of six cities.

City	Temperature in °C
Athens	9
Barcelona	6
Bucharest	-3
Kazan	-12
Kiev	-5
Moscow	-9

(a) Which of these cities had the lowest temperature?

.....
(1)

(b) Work out the difference between the lowest temperature in Barcelona and the lowest temperature in Moscow.

..... °C
(1)

In Podgorica, the lowest temperature was 14 °C higher than the lowest temperature in Bucharest.

(c) Work out the lowest temperature in Podgorica.

..... °C
(1)

(Total for Question 6 is 3 marks)



7 Ahmed buys a rake and some packets of seeds.

The rake costs \$19.50

Each packet of seeds costs \$1.99

Ahmed pays with two \$20 notes and receives \$8.56 change.

Work out the number of packets of seeds Ahmed buys.

.....
(Total for Question 7 is 4 marks)

DO NOT WRITE IN THIS AREA

DO NOT WRITE IN THIS AREA

DO NOT WRITE IN THIS AREA



DO NOT WRITE IN THIS AREA

DO NOT WRITE IN THIS AREA

DO NOT WRITE IN THIS AREA

8 A box contains 3 red bricks, 2 yellow bricks and 7 orange bricks.
There are no other bricks in the box.

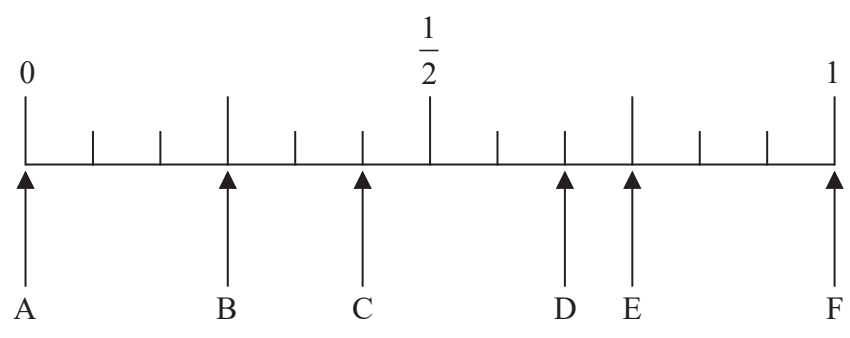

Edward is going to take at random a brick from the box.

Write down the letter of the arrow that points to the probability that he takes

(i) a red brick,

.....

(ii) a yellow brick or an orange brick,

.....

(iii) a brick that is **not** blue,

.....

(iv) a green brick.

.....

(Total for Question 8 is 4 marks)



9 Tim arrived at an airport in Boston at 4 45 pm.

(a) Write this time using the 24-hour clock.

.....
(1)

Tim caught a plane to New York from Boston.

The plane left at 6 55 pm.

(b) Work out how many minutes it was from the time when Tim arrived at the airport to the time when the plane left.

.....minutes
(1)

The plane left Boston at 6 55 pm.

The plane took 1 hour 24 minutes to reach New York.

(c) What was the time in Boston when the plane reached New York?

.....
(1)

(Total for Question 9 is 3 marks)



DO NOT WRITE IN THIS AREA

DO NOT WRITE IN THIS AREA

DO NOT WRITE IN THIS AREA

10 Primrose throws a biased dice 240 times.
The table gives information about her results.

Score	Frequency
1	90
2	30
3	18
4	48
5	16
6	38

Primrose is going to draw a pie chart for her results.

(a) Work out the angle in the pie chart for a score of 6

.....
(2)

Donatello spins a biased 5-sided spinner a number of times.
He draws a pie chart for his results.

The table gives the angle in the pie chart for each number the spinner lands on.

Number on spinner	Angle in pie chart
1	60°
2	80°
3	100°
4	70°
5	50°

The spinner lands on 3 a total of 250 times.

(b) Work out the total number of times Donatello spins the spinner.

.....
(2)

(Total for Question 10 is 4 marks)



11 (a) Simplify $t + t + t$

.....
(1)

(b) Simplify $3p \times 5q$

.....
(1)

(c) Expand $4(y - 5)$

.....
(1)

(d) Solve $\frac{8x}{5} = 9.2$

$x =$
(2)

(Total for Question 11 is 5 marks)

12 Here is a trapezium.

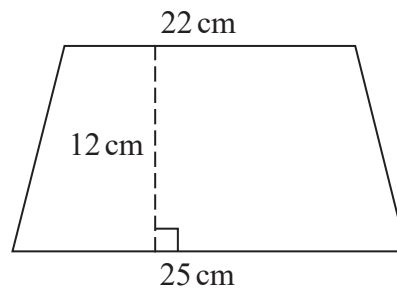

Diagram **NOT**
accurately drawn

Work out the area of the trapezium.

.....cm²

(Total for Question 12 is 2 marks)



DO NOT WRITE IN THIS AREA

DO NOT WRITE IN THIS AREA

DO NOT WRITE IN THIS AREA

13 Jiang left her home at 1 pm to cycle to a bicycle shop.
Here is the travel graph for Jiang's journey to the bicycle shop.

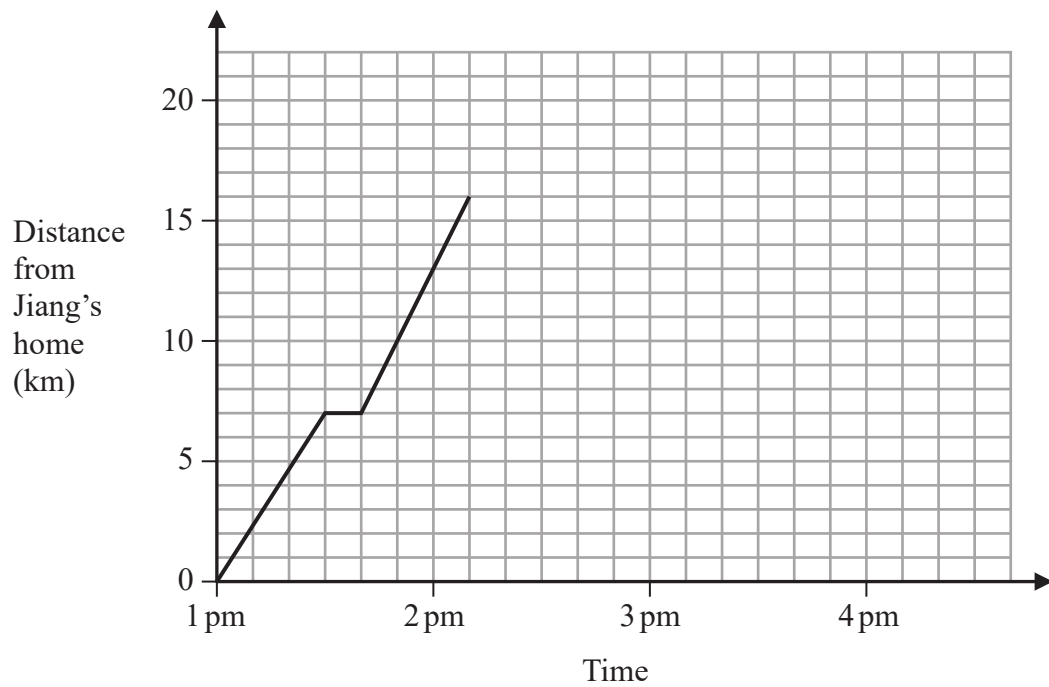

Jiang stopped on the way to the bicycle shop for a rest.

(a) For how long did she stop for a rest?

.....minutes
(1)

(b) Work out Jiang's average speed, in kilometres per hour, for that part of her journey from her home to when she stopped for a rest.

.....kilometres per hour
(2)

Jiang spent 40 minutes at the bicycle shop.
She then cycled home at a constant speed.
She got to her home at 3 50 pm.

(c) Show all this information on the graph.

(2)

(Total for Question 13 is 5 marks)



14

1 euro = 1.25 Japanese Yen

1 Canadian dollar = 0.72 euros

Natsuko has 360 Japanese Yen.
Zoe has 425 Canadian dollars.

Natsuko and Zoe each change their money into euros.

Zoe gets more euros than Natsuko.
How many more?

.....euros

(Total for Question 14 is 3 marks)

DO NOT WRITE IN THIS AREA

DO NOT WRITE IN THIS AREA

DO NOT WRITE IN THIS AREA



DO NOT WRITE IN THIS AREA

DO NOT WRITE IN THIS AREA

DO NOT WRITE IN THIS AREA

15 Aarav is going to buy a laptop.

The laptop costs 39 000 rupees.

Aarav already has $\frac{1}{3}$ of the cost of the laptop.

He needs to save for the rest of the cost.

Aarav has a Saturday job.

Each Saturday his pay is 5300 rupees.

He is going to save 55% of his pay.

Work out the number of Saturdays Aarav must work until he has saved the rest of the cost of the laptop.

.....
(Total for Question 15 is 5 marks)



16 Three numbers have

- a mean of 17
- a median of 20
- a range of 27

Find the three numbers.

..... , ,

(Total for Question 16 is 3 marks)

DO NOT WRITE IN THIS AREA

DO NOT WRITE IN THIS AREA

DO NOT WRITE IN THIS AREA



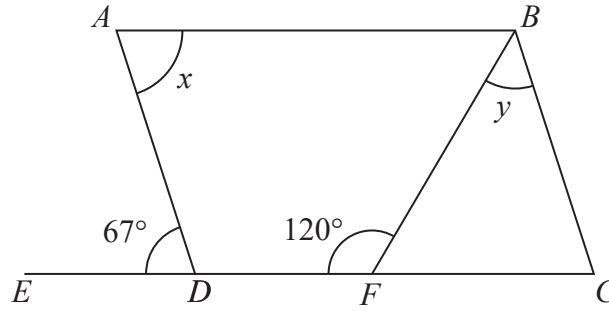

Diagram **NOT** accurately drawn

ABCD is a parallelogram.
EDFC is a straight line.

(a) (i) Write down the size of angle *x*.

..... °

(ii) Give a reason for your answer.

.....
 (2)

(b) Work out the size of angle *y*.

..... °

.....
 (2)

(Total for Question 17 is 4 marks)



18 The table gives information about the number of trees in each of 20 gardens.

Number of trees	Frequency
0	2
1	7
2	3
3	4
4	3
5	1

Work out the total number of trees in these gardens.

.....
(Total for Question 18 is 2 marks)

19 Charlotte earns £8.50 per hour.
She gets a pay rise of 6%

Work out how much Charlotte earns per hour after her pay rise.

£.....

(Total for Question 19 is 3 marks)



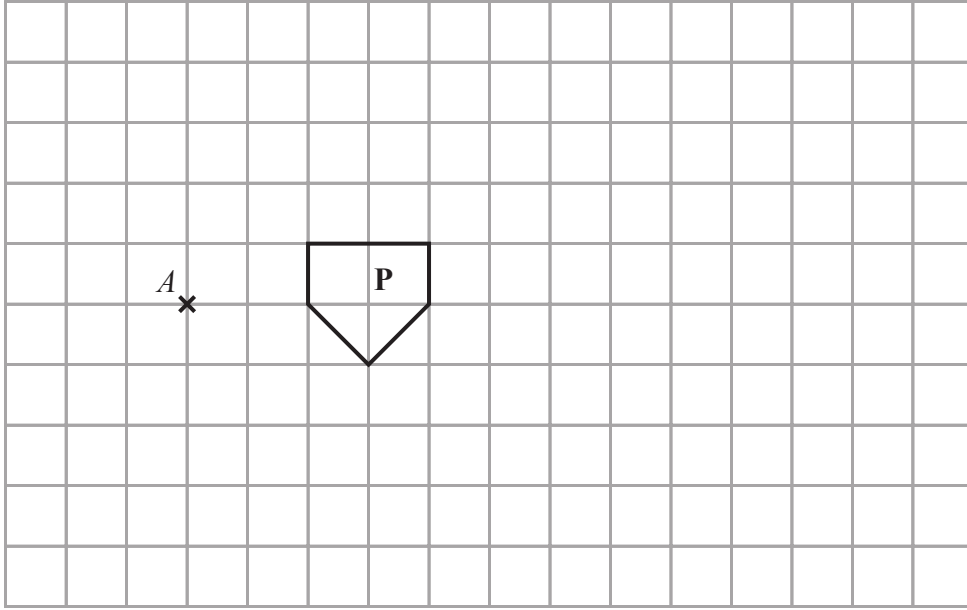

(a) On the grid, enlarge shape **P** with scale factor 3 and centre *A*.

(2)

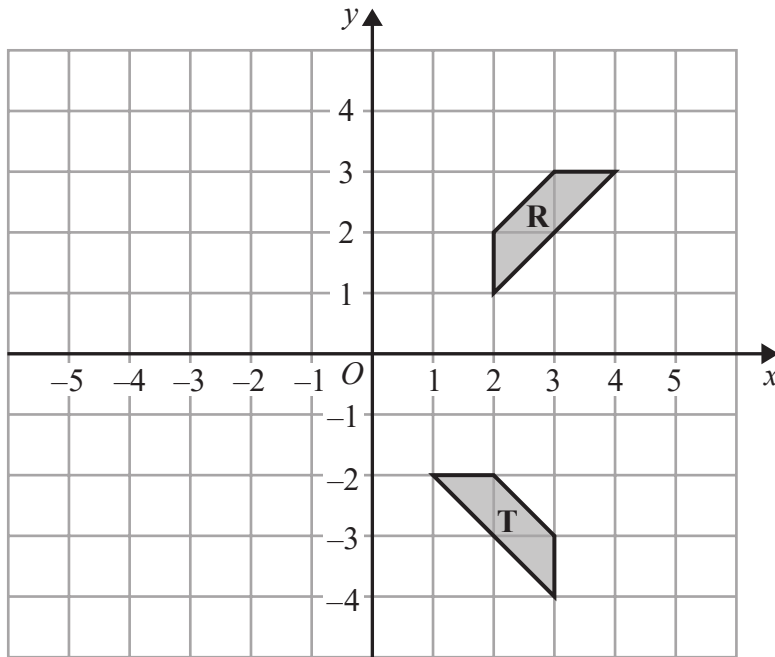

(b) Describe fully the single transformation that maps shape **R** onto shape **T**.

(3)

(Total for Question 20 is 5 marks)

DO NOT WRITE IN THIS AREA

DO NOT WRITE IN THIS AREA

DO NOT WRITE IN THIS AREA



21 Solve the simultaneous equations

$$\begin{aligned}y &= 4x \\ 7x - y &= -13.5\end{aligned}$$

Show clear algebraic working.

$x = \dots\dots\dots$

$y = \dots\dots\dots$

(Total for Question 21 is 3 marks)

DO NOT WRITE IN THIS AREA

DO NOT WRITE IN THIS AREA

DO NOT WRITE IN THIS AREA



DO NOT WRITE IN THIS AREA

DO NOT WRITE IN THIS AREA

DO NOT WRITE IN THIS AREA

22 A , B and C are three cities.

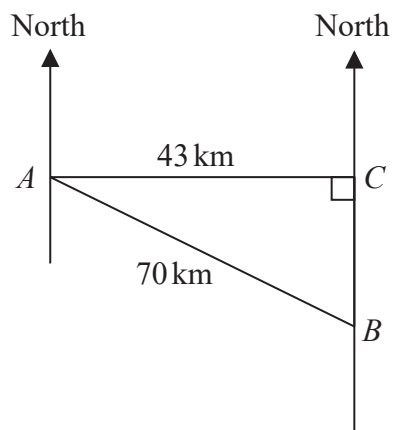

Diagram **NOT** accurately drawn

City C is due east of city A and due north of city B .
City A is 43 km from city C and 70 km from city B .

Work out the bearing of city B from city A .
Give your answer correct to the nearest degree.

.....
(Total for Question 22 is 4 marks)



23 (a) Simplify $m^7 \times m^4$

.....
(1)

(b) Simplify $(3a^2b^4)^3$

.....
(2)

(c) Expand and simplify $4(g - 2h) + 5(2g - 3h)$

.....
(2)

(d) Expand and simplify $(y - 7)(y + 5)$

.....
(2)

(Total for Question 23 is 7 marks)



DO NOT WRITE IN THIS AREA

DO NOT WRITE IN THIS AREA

DO NOT WRITE IN THIS AREA

24 Write 280 as a product of its prime factors.
Show your working clearly.

.....
(Total for Question 24 is 3 marks)



25

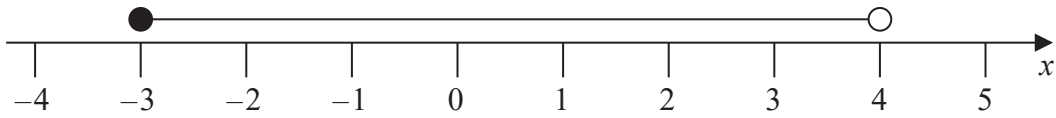

An inequality in x is shown on the number line.

(a) Write down this inequality.

.....
(2)

(b) Solve the inequalities $-5 \leq 2p + 3 < 13$

.....
(3)

(Total for Question 25 is 5 marks)

TOTAL FOR PAPER IS 100 MARKS

DO NOT WRITE IN THIS AREA

DO NOT WRITE IN THIS AREA

DO NOT WRITE IN THIS AREA

